

Foglio 2  
 SX16A.SchDoc

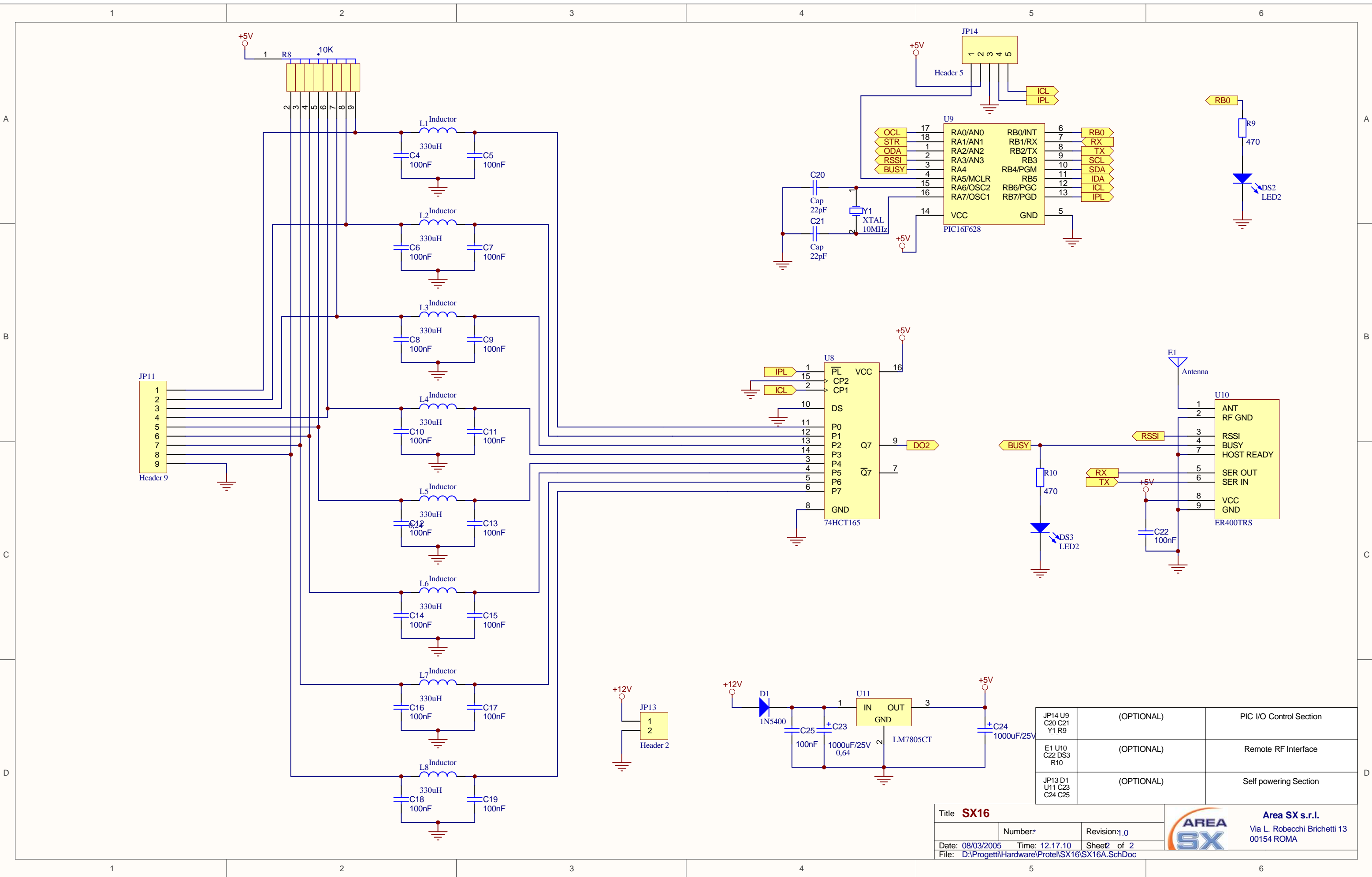

JP14 U9 C20 C21 Y1 R9	(OPTIONAL)	PIC I/O Control Section
E1 U10 C22 DS3 R10	(OPTIONAL)	Remote RF Interface
JP13 D1 U11 C23 C24 C25	(OPTIONAL)	Self powering Section

Title **SX16**

Number*	Revision:1,0
Date: 08/03/2005	Time: 12.17.10
File: D:\Progetti\Hardware\Protel\SX16\SX16A.SchDoc	Sheet 2 of 2

